

Sketch of the beam

L 100[mm] beam length
 W 38.1[mm] beam width
 T 3.81[mm] beam thickness
 p 1987[kg/m³] density
 Emod 57[GPa] Young's modulus
 D 1.05[mm] Initial displacement

Hi everyone:

The initial displacement $D=1.05\text{mm}$, is placed on the end of the cantilever beam, to solve the velocity response of the beam end. First, I select space dimension 2D, and add physics Beam, but the simulation result is wrong, when I select space dimension 2D, and add physics Solid Mechanics (solid), the simulation result also is wrong, the velocity curve is increasing against time. Now I select space dimension 3D, and add physics Beam, but the simulation result is not the same to the experimental result and analytical result. I am confused. Hope some one give me a advice, thank you! Details see attachment.

1. the first step, select space dimension --**3D**
2. next, select add physics -- **beam**
3. next, select study type – stationary
4. next, -- finish
5. right click, --global definitions -- select – parameter, as bellows: L 100[mm] beam length; W; 38.1[mm] beam width; T 3.81[mm] beam thickness; p 1987[kg/m³] density; Emod 57[GPa] Young's modulus; D 1.05[mm] Initial displacement
6. Next right click, --geometry1 – select – block1, in the width item type L; in the width item type W; in the width item type T.
7. Next right click, linear elastic material1, select damping1, in the damping type: select isotropic loss factor, select user defined, type:0.004

8. next, right click, material, select material1, click basic properties, select density, type: p ; click solid mechanics, and click linear elastic material, select Young's Modulus and Poisson's and add to material, type Emod and 0.3, respectively.
9. next, right click, beam, select fixed constraint1, select point 1,2,3 and 4
10. next, right click, beam, select initial values2, in the edge selection, select 11; and in the displacement field(z) type: D
11. next, right click, study1, select compute
12. next, right click, untitled.mph(root), select add study2, in the studies items, select time-dependent, click finish
13. next, in the study2, in the step1: time dependent, in the study settings, times: type range(0, 0.001,1); in the values of dependent variables, select initial values of variables solved for , in the method: select solution; in the study: select study1, stationary
14. next, right click, study2, select compute
15. next, right click, results, select 1D plot group and right click 1D plot group, select point graph, in the data set: solution2, in the selection, type 8, in y-axis data, expression: type wt, unit: m/s, and click plot.

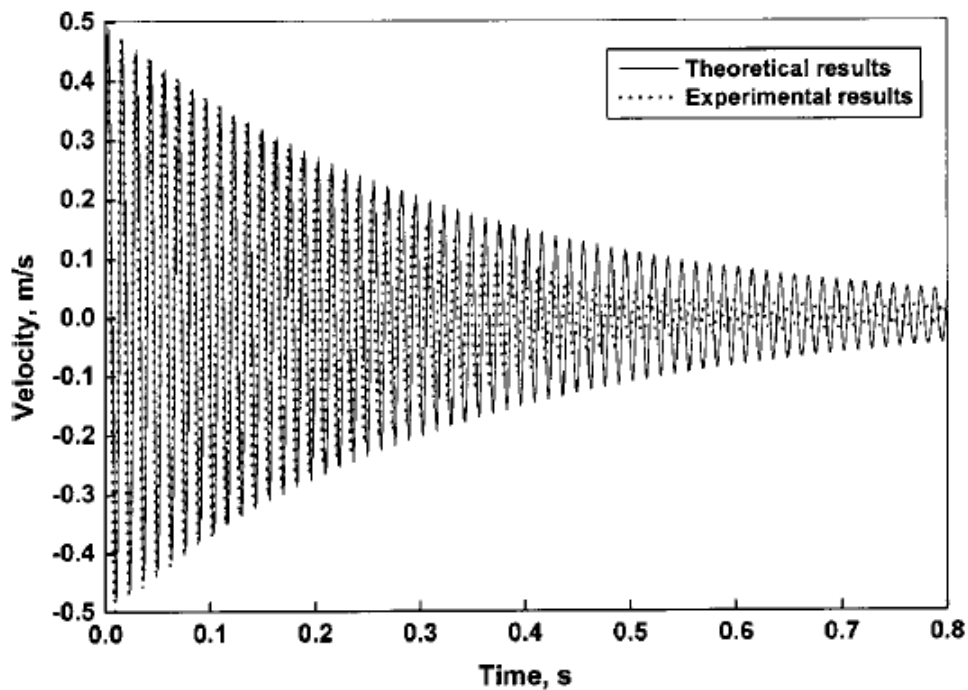

☰ Global Definitions

1. Pi Parameters

Name	Expression	Value
L	100[mm]	0.10000 m
W	38.1[mm]	0.038100 m
T	3.81[mm]	0.0038100 m
p	1987[kg/m ³]	1987.0 kg/...
Emod	57[GPa]	5.7000E10 ...
D	1.05[mm]	0.0010500 m

2.

 Geometry 1

3.

 Block 1 (*blk1*)

Size and Shape

Width: m

Depth: m

Height: m

4.

 Materials

5.

 Material 1 (*mat1*)

Material Contents

Property	Name	Value
Density	rho	p
Young's modulus	E	Emod
Poisson's ratio	nu	0.3

6.

 Linear Elastic Material 1

7.

 Damping 1

Damping Settings

Damping type:

Isotropic structural loss factor:
 η_s
 1

8.

9.  Fixed Constraint 1

Selection: Manual

- 1
- 2
- 3
- 4



10.

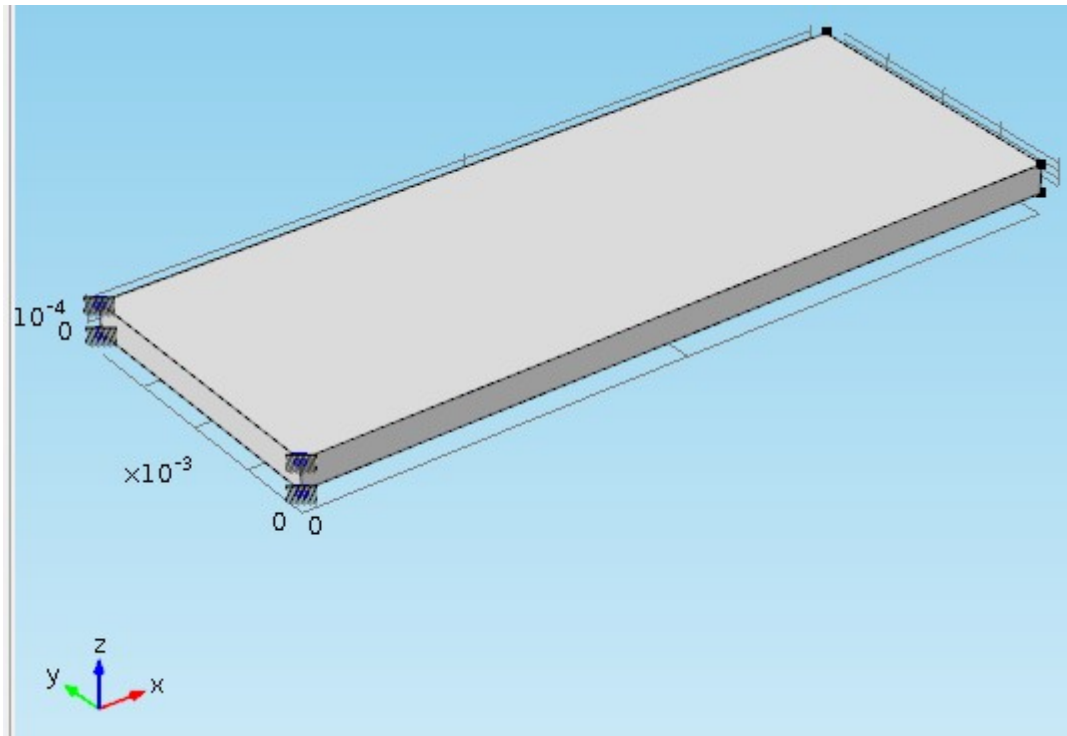

11. Initial Values 2

Displacement field:

0	x	m
0	y	
-D	z	

12.

Edge Selection

Selection: Manual

- 11



13.

14.

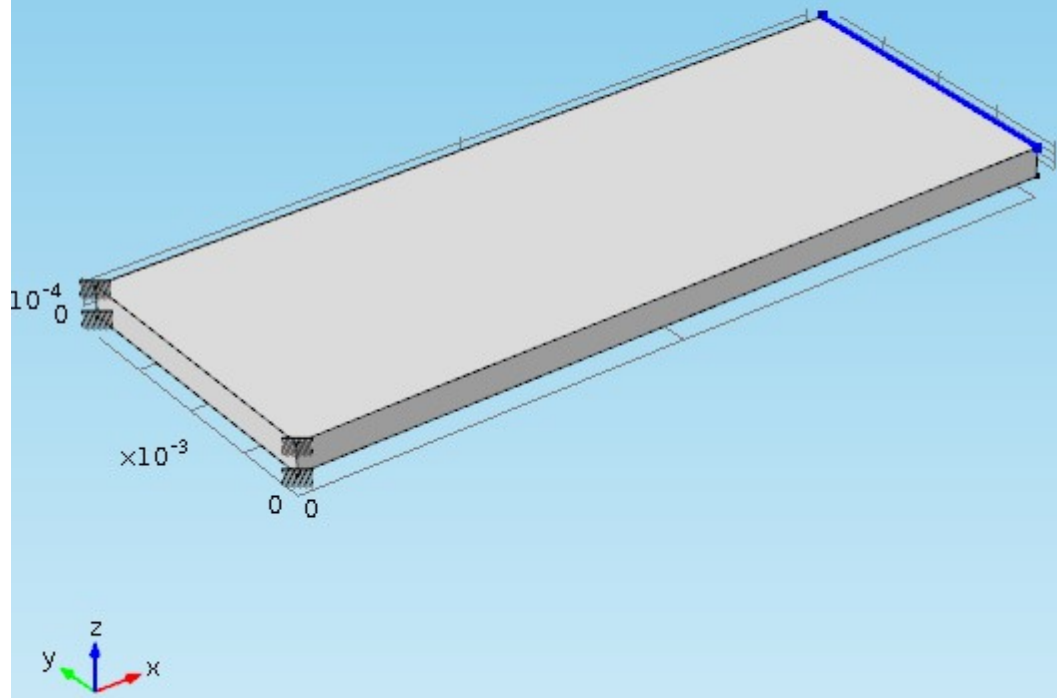

15

- Beam (*beam*)
 - Linear Elastic Material 1
 - Damping 1
 - Cross Section Data 1
 - Section Orientation 1
 - Free 1
 - Initial Values 1
 - Fixed Constraint 1
 - Initial Values 2
- Mesh 1

16

- Study 1
 - Step 1: Stationary
 - Solver Configurations
 - Solver 1

17 Compute:

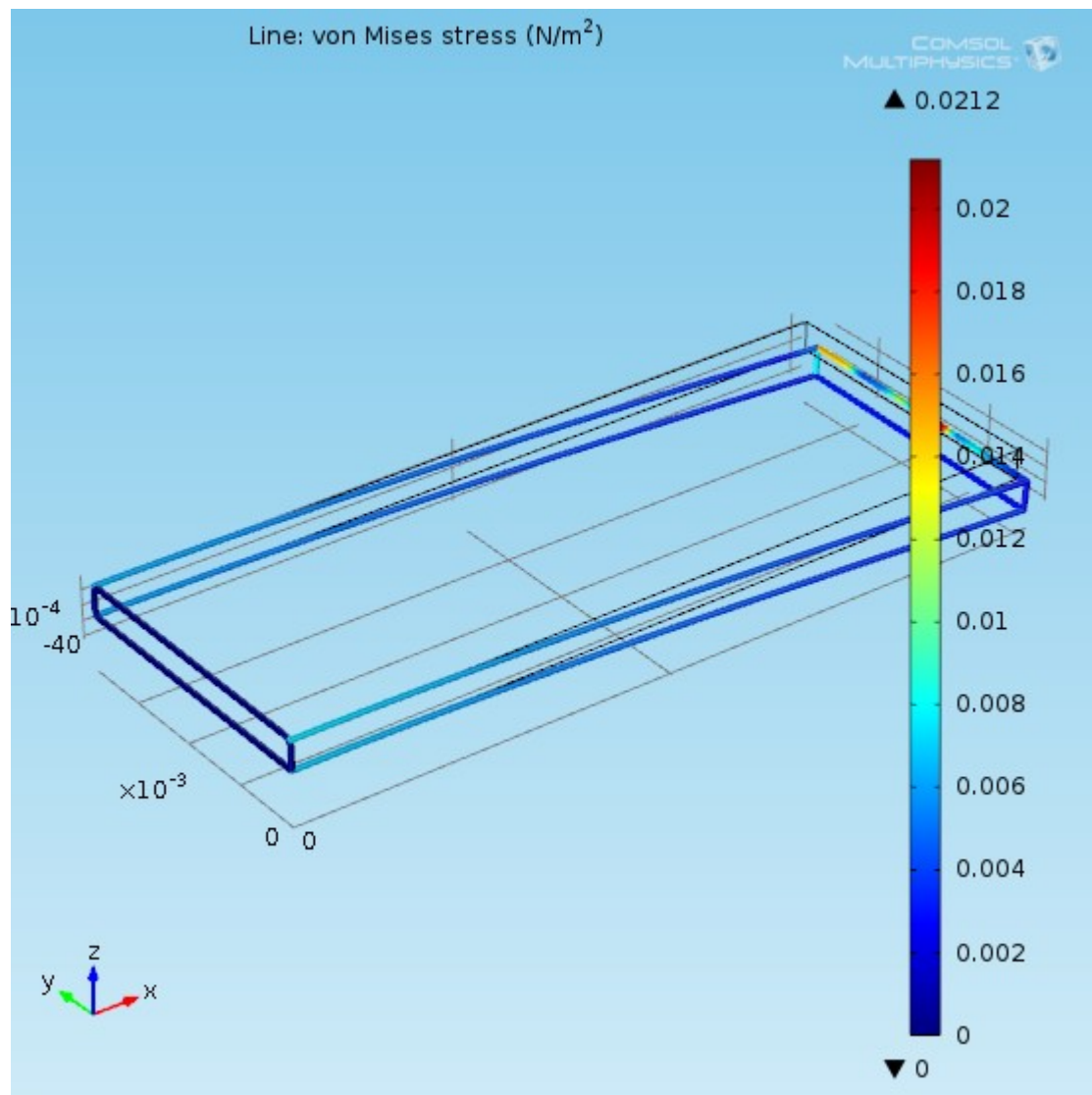

Study 2

- Step 1: Time Dependent
- Solver Configurations
 - Solver 2
 - Compile Equations: Time 1
 - Dependent Variables 1
 - Time-Dependent Solver 1
 - Direct
 - Advanced
 - Fully Coupled 1

18

▼ Study Settings

Times: s

Relative tolerance:

19

Values of Dependent Variables

Initial values of variables solved for

Method: Solution

Study: Study 2

Time: Automatic

20.

21 compute:

1D Plot Group 15

22 Point Graph 1

Data

Data set: Solution 2

Time selection: All

Selection

Selection: Manual

8

y-Axis Data

Expression: wt

Unit: m/s

Description: Structural velocity field, z component

23 Parameters

24

Point Graph: Structural velocity field, z component (m/s)

